

DORMAKTM

LIFETIME GARDEN EQUIPMENTS

CATALOGUE
2023

**A RUBUST, RELIABLE
AND EFFICIENT RANGE OF
PRODUCTS**



Series
HOME

Series
PRO

www.dormak.pt

DORMAK

LIFETIME GARDEN EQUIPMENTS



A factory with a versatile geometry

Dormak's main production unit has an important competitive advantage, which is the diversity of tasks it handles, from cutting thick steel by laser to manual final assembly. Processes such as welding, polishing, painting and drying are steps developed, optimized and controlled internally. No key part of the machine is manufactured outdoors, with the exception of the engine, which reduces the risk of breakdown on assembly lines.

This unit, located in Vagos, Portugal, was expanded in 2022, now totaling 9000m². The plan for the coming years is even more ambitious, as a response to a growing market demand.

The positioning of Dormak's products is very clear: superior quality with thicker steel than competitor's machines, all at a fair price. "We don't make the lowest priced products", says CEO. "Our machines must be reliable, easy to use and serviceable. This is why, for example, the milling cutters of our tillers are screwed together and not welded, so that they can be repaired even after fifteen years of use. Our motivation is to create a brand where we build the machines ourselves with all our industrial know-how."

This strategy has proven to be successful in recent years, with Dormak consistently achieving annual growth above 70%. The European interest in products closer to home, with low logistical costs/better delivery times, and higher quality is increasing.



GARDEN



FOREST



AGRICULTURE



WATER



LAWN
TRACTORS

04 LAWN MOWERS

12 SCARIFIERS

16 HIGH GRASS MOWERS

20 SHREDDERS

26 LOG SPLITTERS

32 TILLERS

40 MOTOSPRAYERS

46 RIDERS

50 GARDEN TRACTORS

LAWN MOWERS

Prepare the perfect garden. Lawn mowers must be especially suitable for every lawn whether small, medium or large dimensions. With our Dormak range, you can enjoy petrol and electric lawn mowers, choose the power class and version that best meets your specific needs.

DORMAKTM



ROBUST

The build quality is present in all models, with reinforced chassis for above average durability.

ERGONOMIC

Prepared to guarantee the highest comfort and maneuverability.

SAFE

Machines prepared and tested for different types of use and with effective security systems.

THE RANGE

CR43 - CR48 - CR55

highlight **CR 48**

DORMAKTM
LIFETIME GARDEN EQUIPMENTS

Series
HOME

Series
PRO

- GARDEN
- FOREST
- AGRI
- WATER
- LAWN TRACTORS



DORMAK DETAILS



Bold front with interior wheel protection



Handlebar grip in plastic



Bag lid with ergonomic handle

A large part of Dormak's lawn mower line was redesigned based on the success of the CR 43 model, with the focus being to build practical and reliable machines for areas of any size. The bag lid and handlebar grip have been modified to improve user comfort. The wheel covers, a common element in the range, is a Dormak detail already recognized in the market.



LAWN MOWERS



small areas

For low intensity tasks



CR 43 LS



HANDLEBARS INTEGRATED INTO THE CHASSIS



CENTRAL TRANSPORT HANDLE



	CR 43 LS
Engine	AC 1800 230V
Displacement/Power	1800 W
Drive system	Push
Cutting width	430 mm
Cutting height	18 - 60 mm
Recommended Use	800 m ²
Capacity	55 L
Deck Type	Plastic
Cutting Height Adjustment	Central (6 Positions)
Wheels	F:180 mm B:230 mm
Mulching Kit	With mulching cover
Weight	23 Kg

NEW

CR 48 & CR 55



EVOLUTION STEP BY STEP...

Dormak followed an ambitious strategy of updating a large part of its range of lawn mowers, to make available more models produces in Europe. The CR 43 project, which took several months to develop and presented sale arguments not seen in any other machine of this size, won awards for innovation and design. Therefore, it only made sense for the rest of the range to be based on the design of this revolutionary machine.

Dormak is proud to be the only lawn mower producer in the Iberian Peninsula, and wants to move a step further. With the new 48 and 55 cm steel decks, entirely manufactured in Portugal, the lawn mowers announced this year have the best design and the boldest front on the market. Thought out to the smallest detail, with the incorporation of the opinion of many professionals in the area almost all the components of the machine were improved. From the bag lid to the hand support, with the inclusion of a front bumper, there are many aspects that were revised and that excites about this new machine.

The market spoke and Dormak listened, presenting this year the result of a year of development, totally centered on the needs of the end consumer.





BASED ON SUCCESS

LAWN MOWER WITH HIGH CUTTING WIDTH

EFFECTIVE AND EASY TO USE

FOR ALL TYPES OF LAWN

THOUGHT OUT IN DETAIL

The new CR 48 and CR 55 lines are now completely made in Portugal, with the exception of the engine. With a modern steel deck designed and pressed by Dormak, all versions of these machines have a new and more accessible bag fitting system, a 360° adjustable handlebar and a new Dormak bag lid, improved to never break with heavy materials that may enter the bag. The lawn mower range now covers necessities of lawns of any size and is positioned for both leisure and professional end consumers.

LAWN MOWERS



48/55CM STEEL DECK



NEW BAG FITTING SYSTEM



BUMPER



PLASTIC HANDLEBAR GRIP

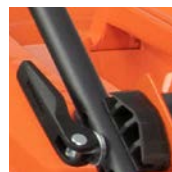

360° ADJUSTABLE HANDLEBAR



PLASTIC LID WITH NEW HANDLE

medium areas

Ideal for
medium/high
intensity tasks



CR 48 H PLUS



	CR 48 L	CR 48 L PLUS	CR 48 BS PLUS	CR 48 H PLUS
Engine	Loncin	Loncin	B&S 500E	Honda GCVx170
Displacement	123 cc	166 cc	140 cc	166 cc
Power	2,2 kW	2,2 kW	2,9 kW	3,6 kW
Driving system	Self-propelled	Self-propelled	Self-propelled	Self-propelled
Cutting width	460 mm	460 mm	460 mm	460 mm
Cutting height	30- 80 mm	30- 80 mm	30- 80 mm	30- 80 mm
Recommended Use	1500 m ²	1500 m ²	1500 m ²	1500 m ²
Capacity	55 L	55 L	55 L	55 L
Bag Type	Dormak	Dormak	Dormak	Dormak
Deck Type	Steel	Steel	Steel	Steel
Cutting height adjustment	Center (7 Positions)	Center (7 Positions)	Center (7 Positions)	Center (7 Positions)
Handlebar Type	Normal	Ergonomic	Ergonomic	Ergonomic
Wheels	F:180 mm B: 230 mm	F:180 mm B: 230 mm	F:180 mm B: 230 mm	F:180 mm B: 230 mm
Bumper	No	Yes	Yes	Yes
Weight	36 Kg	36 Kg	37 Kg	37 Kg

big areas

Ideal for high intensity tasks



CR 55 H PLUS



	CR 55 L PLUS	CR 55 BS PLUS	CR 55 H PLUS
Engine	Loncin	B&S 675 EXI	Honda GCVx200
Displacement	166 cc	163 cc	196 cc
Power	2,9 kW	2,68 kW	4,2kW
Driving system	Self-propelled	Self-propelled	Self-propelled
Cutting width	530 mm	530 mm	530 mm
Cutting height	30- 80 mm	30- 80 mm	30- 80 mm
Recommended Use	3000 m ²	3000 m ²	3000 m ²
Capacity	70 L	70 L	70 L
Bag Type	Net	Net	Net
Deck Type	Steel	Steel	Steel
Cutting height adjustment	Center (7 Positions)	Center (7 Positions)	Center (7 Positions)
Handlebar Type	Ergonomic	Ergonomic	Ergonomic
Wheels	F:180 mm B: 230 mm	F:180 mm B: 230 mm	F:180 mm B: 230 mm
Bumper	Yes	Yes	Yes
Weight	40 Kg	40 Kg	40 Kg

SCARIFIERS

Scarifying removes the moss and the layer that suffocates lawns. This removal encourages healthy root growth by applying water, air and nutrients to the soil. Scarifying in spring and autumn strengthens your lawn!

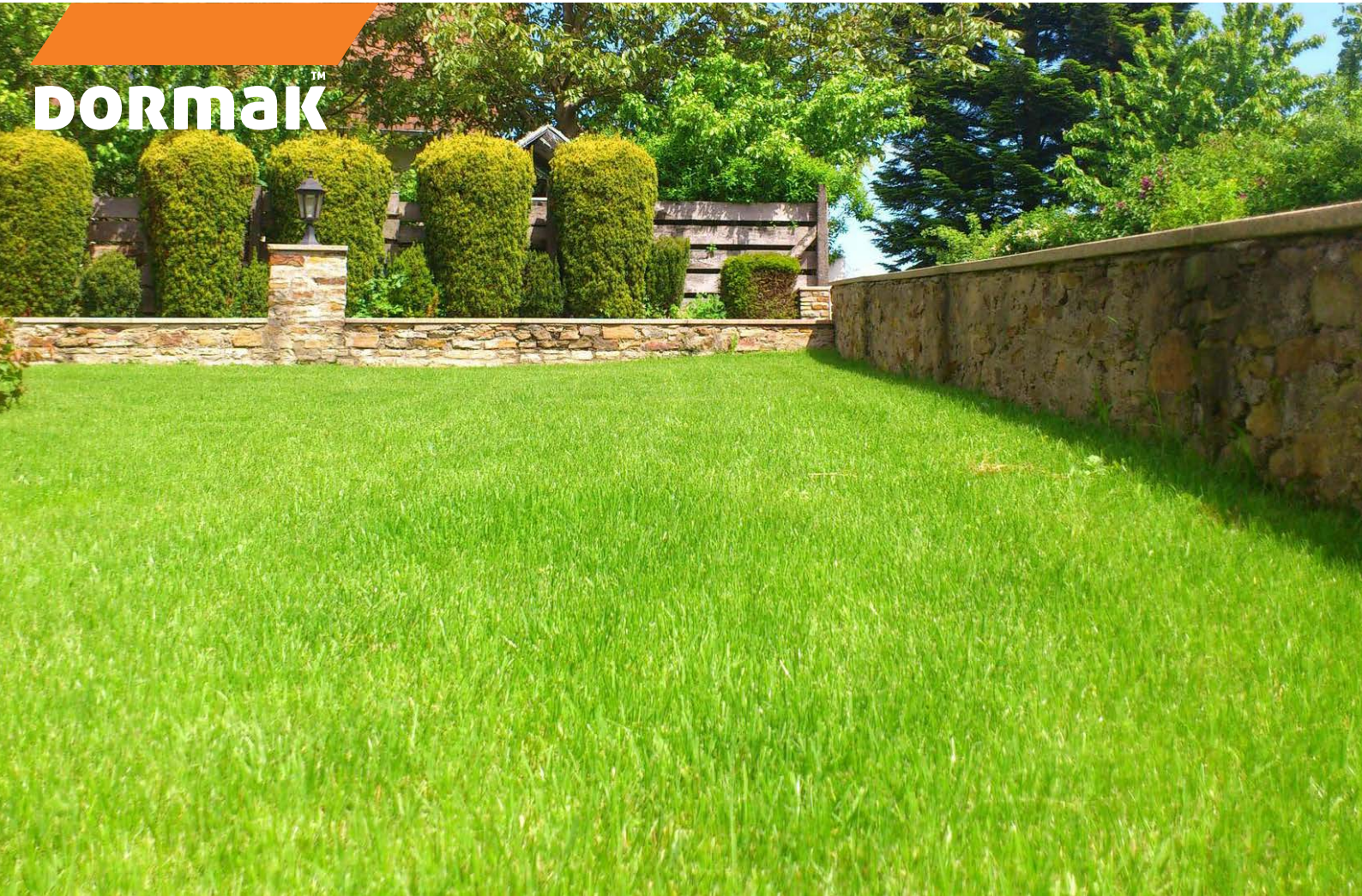

VERSATILITY

Machines with height-adjustable handlebar and central cutting height controller.

PRACTICAL SOLUTION

For quick and easy housekeeping.

COMPACT WHEELS

Equipment prepared and tested for different scenarios of use and with effective security systems.

STEEL PLATFORM

Steel decks for greater strength and durability.

THE RANGE

SC40 - SC45 - SC490 - SC520

DORMAKTM
LIFETIME GARDEN EQUIPMENTS

Series
HOME

Series
PRO

- GARDEN
- FOREST
- AGRI
- WATER
- LAWN TRACTORS

highlight **SC 520 PRO**



DORMAK DETAILS



Professional aluminum wheels or Dormak rims



Centralized cutting height adjustment

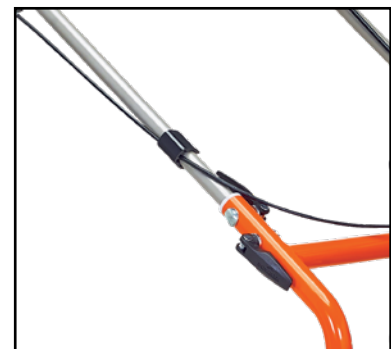

Height-adjustable handlebar

Dormak scarifiers offer a complete range for all areas of work, from 500 to 2500 m², with typical Dormak wheel covers for the smaller models and aluminum wheel covers for the more professional ones. All models have a central or front lever for adjusting the height of the deck and a handlebar that is adjustable to the user's height.

small areas

Ideal for
medium-sized
lawns



SC 45 H



	SC 40 L	SC 45 BS	SC 45 H
Engine	Loncin	B&S CR750	Honda GP160
Displacement	79 cc	163 cc	163 cc
Max. Power	2,5 kW	5 kW	3,6 kW
Working width	400 mm	450 mm	450 mm
Recommended use	500 m ²	500 m ²	500 m ²
Work height adjustment	Central	Central	Central
Blades quantity	17	19	19
Bag	45 L	45 L	45 L
Blade type	Fixed	Fixed	Fixed
Weight	30 kg	45 kg	45 kg

big areas



Ideal for large
lawns

SC 490 PRO



Equipped with
SWINGING BLADES



	SC 490 PRO M SWINGING BLADES	SC 520 PRO H SWINGING BLADES	SC 520 PRO H F FIXED BLADES
Engine	Honda GP 160	Honda GX160	Honda GX160
Displacement	163 cc	163 cc	163 cc
Max. Power	3,6 kW	3,6 kW	3,6 kW
Working width	500 mm	520 mm	520 mm
Recommended use	2500 m ²	2500 m ²	2500 m ²
Work height adjustment	Central	Central	Central
Blades quantity	30	34	21
Bag	-	-	-
Blade type	Swinging	Swinging	Fixed
Weight	55 kg	80 kg	80 kg

-  GARDEN
-  FOREST
-  AGRI
-  WATER
-  LAWN TRACTORS

SCARIFIERS

HIGH GRASS MOWERS

Our equipment is manufactured to be used in difficult working areas, extremely dense vegetation and uneven lawns. Allowing impeccable work with less effort and ensuring maximum safety, these machines can be used for domestic or professional tasks.



DORMAK™



EASY TRANSPORTATION

3 wheel system that allows easy handling and rapid change of course.

CUTTING SYSTEM

Single blade system.

RESISTANT STRUCTURES

Equipment with resistant chassis and deck for long hours of intense work.

THE RANGE

TD50 - EP50 - EP53 - SP51 - SP65

DORMAKTM

LIFETIME GARDEN EQUIPMENTS

Series
HOME

Series
PRO

- GARDEN
- FOREST
- AGRI
- WATER
- LAWN TRACTORS

highlight **SP 65 H**



DORMAK DETAILS



Transmission box for 5F+1R speeds



Large or pneumatic wheels



Height-adjustable front wheel

Dormak high grass mowers have always been a differentiating product in the market. Developed to work with high grass and deal with more difficult lawns, these machines are always **EQUIPPED** with large or pneumatic wheels for easy transport, and a front smaller wheel for reinforced support. All models are self-propelled.



HIGH GRASS MOWERS

small areas

Ideal for fields
of medium
dimensions

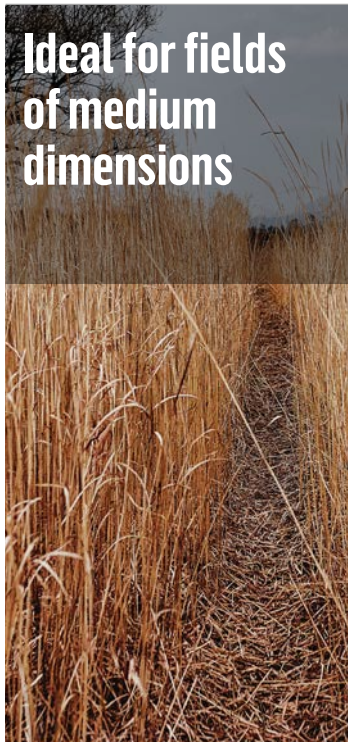

TD 50 L



	TD 50 L	EP 50 BS	EP 53 H	EP 50 BS - 4	EP 53 H - 4
Engine	Loncin	B&S 675 EXi	Honda GCVx170	B&S 650 EXi	Honda GCVx170
Power	166 cc	163 cc	166 cc	165 cc	166 cc
Displacement	2,9 kW	2,9 kW	3,3 kW	2,9 kW	3,6 kW
Working width	520 mm	520 mm	520 mm	520 mm	510 mm
Recommended use	2000 m ²	2000 m ²	2000 m ²	2000 m ²	2000 m ²
Work height adjustment	3 positions	3 positions	3 positions	3 positions	3 positions
Cutting system	Blade	Blade	Blade	Blade	Blade
Speed	1F	1F	1F	1F	1F
Cutting height	40 - 80 mm	40 - 80 mm	40 - 80 mm	45 - 90 mm	45 - 90 mm
Clutch	Yes	Yes	Yes	Yes	Yes
Transmission type	Belt + transmission Box	Belt + Transmission Box	Belt + Transmission Box	Belt + Transmission Box	Belt + Transmission Box
Deck	Steel	Steel	Steel	Steel	Steel
Driving system	Self-propelled	Self-propelled	Self-propelled	Self-propelled	Self-propelled
Tipe wheels	Plastic with bushing	Plastic with bushing	Plastic with bushing	Plastic with bushing	Plastic with bushing
Weight	50 kg	50 kg	50 kg	51 kg	51 kg

big areas

Ideal for fields
of big
dimensions



SP 65 H



	SP 51 BS	SP 65 H
Engine	B&S 850	Honda GCVx200
Power	190 cc	201 cc
Displacement	3,6 kW	4,2 kW
Working width	520 mm	620 mm
Recommended use	2500 m ²	3000 m ²
Work height adjustment	4 positions	4 positions
Cutting system	Blade	Blade
Speed	4F + 1T	4F + 1T
Cutting height	34 - 120 mm	34 - 120 mm
Clutch	Yes	Yes
Transmission type	Belt + Transmission Box	Belt + Transmission Box
Deck	Steel	Steel
Driving system	Self-propelled	Self-propelled
Tipe wheels	Plastic wheels with bushing	Pneumatic Wheel
Weight	60 kg	74 kg

SHREDDERS

Intended for ecology and reuse of organic materials, the shredders carry out your composting tasks. Choose between one of the available electric, combustion or tractor models, the needed power and destroy all organic matter such as branches, pruning or leaves, leaving your space clean whether it is a garden, vegetation, orchard, olive grove, among others.



DORMAKTM

EASY TRANSPORTATION

Handle and pair of wheels that allow easy transport of the equipment.

CUTTING SYSTEM

Triangular blades or hammers to destroy efficiently all types of substances.

BLADES TREATMENT

Low temperature tempered blades to obtain extremely high hardness indexes.

VENTILATION SYSTEM

Ventilation system designed and engineered to optimize material flow inside the shredder.

THE RANGE

SH40 - SH50 - SH75 - SH85

DORMAKTM
LIFETIME GARDEN EQUIPMENTS

Series
HOME

Series
PRO

- GARDEN
- FOREST
- AGRI
- WATER
- LAWN TRACTORS

highlight SH 85 H



DORMAK DETAILS



2-legged support table



4 positions for output tunnel



Ergonomic handle

Dormak shredders, a long and one of the most distinguishable line of products from the brand, offer great stability during usage through a support table with 2 legs instead of 1. The output tunnel can be adjusted to 4 different directions by the user, offering complete flexibility. All the models in the range are easy to transport due to the top or side handle located on the entry tunnel.

MADE IN EUROPE

SHREDDER

low shredding

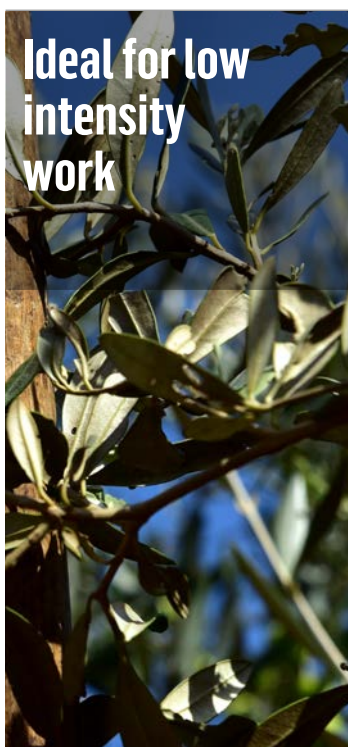

Ideal for low intensity work

SH 50 H



	SH 40 E	SH 50 SXL	SH 50 SX BS	SH 50 SX H
Engine	Electric 2200 W	Loncin	B&S CR750	Honda GP 160
Displacement	-	196 cc	163 cc	163 cc
Power Max.	2200 W	4,1 kW	3,6 kW	3,6 kW
Cutting system	2 Blades	1 blade + 4 hammers	1 blade + 4 hammers	1 blade + 4 hammers
Cutting diameter	40 mm	50 mm	50 mm	50 mm
Shredding capacity	1,4 m ³ /h	1,9 m ³ /h	1,9 m ³ /h	1,9 m ³ /h
Weight	70 Kg	67 Kg	67 Kg	67 Kg

medium shredding

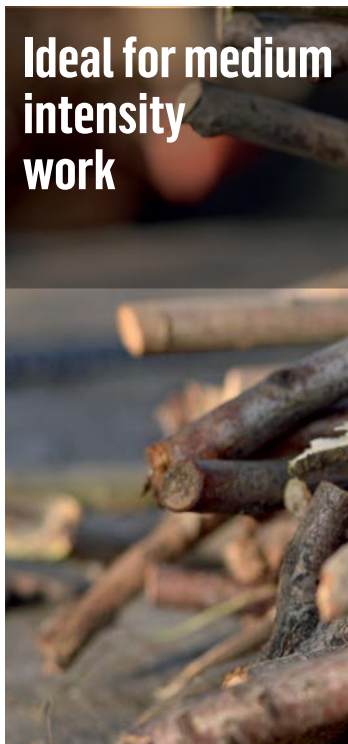

Ideal for medium intensity work

SH 75 BS

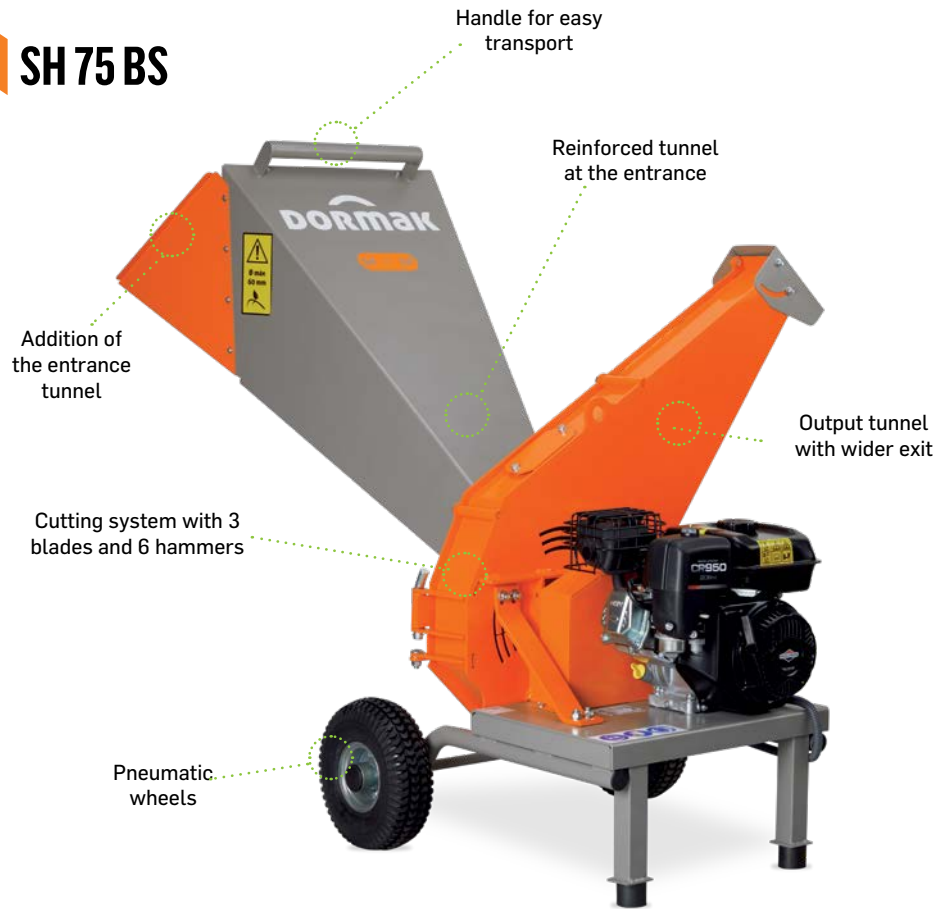

	SH 75 SXL	SH 75 SX BS	SH 75 SX H
Engine	Loncin	B&S CR950	Honda GP200
Displacement	196 cc	208 cc	196 cc
Power Max.	4,1 kW	4,9 kW	4,3 kW
Cut system	3 blades + 6 hammers	3 blades + 6 hammers	3 blades + 6 hammers
Cutting diameter	65 mm	65 mm	65 mm
Shredding capacity	3,5 m ³ /h	3,5 m ³ /h	3,5 m ³ /h
Weight	80 Kg	80 Kg	80 Kg

intense shredding

Ideal for high intensity work



SH 85 PTO



**3-POINT SYSTEM
ATTACHABLE TO TRACTOR**

Recommended for tractor
<50 Hp (a 1500 rpm)



	SH 85 L	SH 85 SX H	SH 85 PTO
Engine	Loncin	Honda GX 390	PTO
Displacement	389 cc	389 cc	-
Power Max.	8,2 kW	11,1 kW	-
Cutting system	3 blades + 9 hammers	3 blades + 9 hammers	3 blades + 9 hammers
Cutting diameter	80 mm	80 mm	80 mm
Shredding capacity	5 m ³ /h	5 m ³ /h	5 m ³ /h
Weight	130 Kg	130 Kg	130 Kg

SHREDDER



LOG SPLITTERS

A perfect tool to cut logs. Effortlessly and safely cut the firewood for your fireplace. Ideal for both leisure and private use with smaller logs and for professionals with an objective to sell the wood. Dormak offers a wide range from 8 to 15 tons of force, with equipment of high resistance, very productive and reliable.



DORMAKTM

3 POSITIONS

Possibility of cutting wood with the machine placed in a vertical, horizontal or oblique position.

SPEED

Variable speed system.

WHEELS

Kit of wheels for easy transportation, making it easy to move the machine to difficult areas.

VARIOUS POWER SUPPLY SYSTEMS

Range with various power supply alternatives such as combustion, electric, and 3-point (tractor) system.

THE RANGE

RL8 - RL10 - RL12 - RL15

DORMAKTM
LIFETIME GARDEN EQUIPMENTS

Series
HOME

Series
PRO

- GARDEN
- FOREST
- AGRI
- WATER
- LAWN TRACTORS

highlight **RL 12 H3**



DORMAK DETAILS

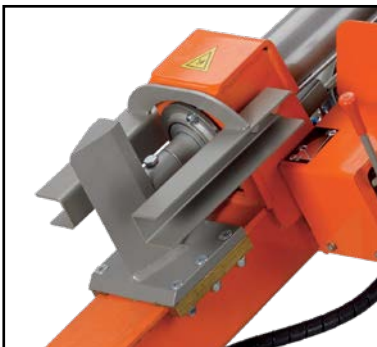

Reinforced cutting wedge



Levers for speed control and safety

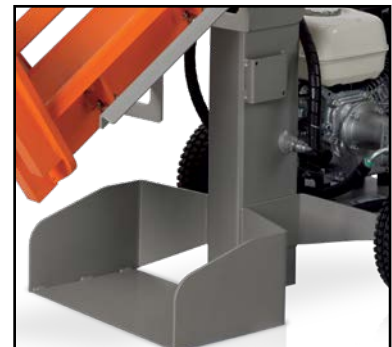

Tunnel with reinforced support

Dormak log splitters offer a complete range adaptable to the needs of each consumer. Include a variable speed system, controlled by two levers located on the top of the frame, a cutting wedge that can handle logs of all sizes and are very easy to handle.



LOG SPLITTERS

8/10 tonnes

Ideal for lighter works



RL 10 BS

Reinforced cutting wedge

Control levers

Reinforced iron support base

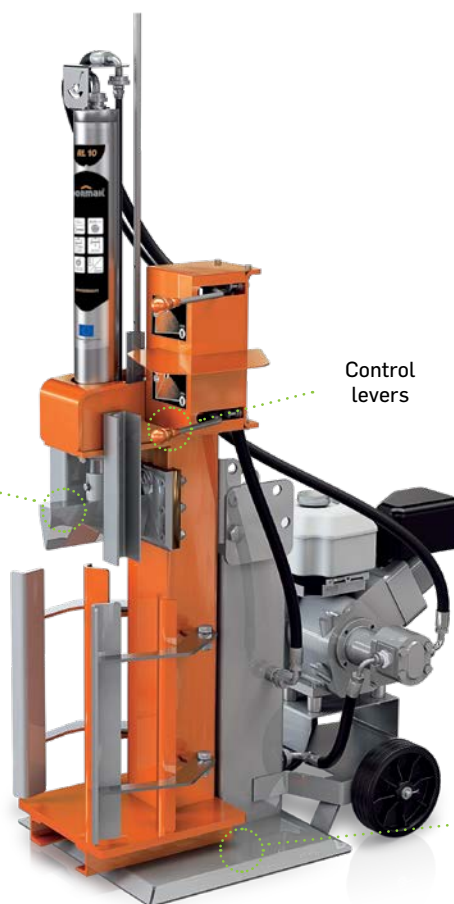

	RL 8 HRZ	RL 10 EL	RL 10 BS
Engine	Electric	Electric	B&S CR950
Displacement	-	-	208 cc
Power	1,8 kW	2,2 kW	4,75 kW
Max. pressure	8 ton	10 ton	10 ton
Max. diameter	360 mm	360 mm	360 mm
Speed	Variable	Variable	Variable
Wheels	2	2	2
Hydraulic Oil Tank Capacity	8.5 L	6.5 L	6.5 L
Maximum length of logs	550 mm	550 mm	550 mm
Working positions	1	1	3
Weight	130 Kg	130 Kg	130 Kg

12 tonnes



Ideal for intense and professional work

RL 12 H3

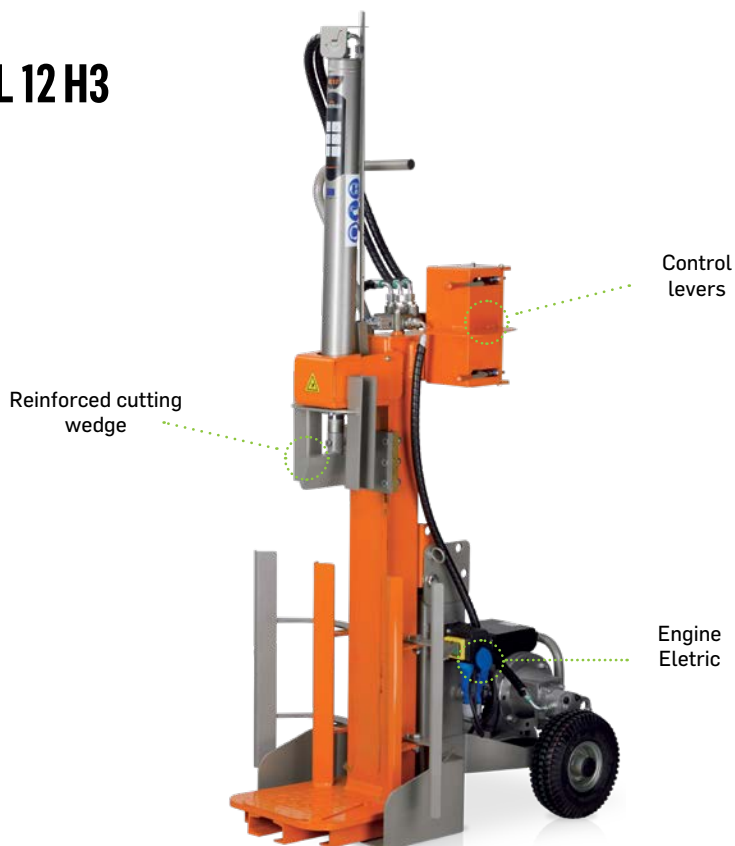

	RL 12 EL	RL 12 H	RL 12 BS	RL 12 H3
Engine	Electric	Honda GX160	B&S CR950	Honda GP 200
Displacement	-	163 cc	208 cc	196 cc
Power	2200 W	3,6 kw	2,2 kW	4,3 kW
Max. pressure	12 ton	12 ton	12 ton	12 ton
Max. diameter	425 mm	425 mm	425 mm	4250 mm
Speed	Variable	Variable	Variable	Variable
Wheels	2	2	2	2
Hydraulic Oil Tank Capacity	7,5 L	7,5 L	7,5 L	7,5 L
Maximum length of logs	700 mm	700 mm	700 mm	700 mm
Working positions	3	3	3	3
Weight	172 Kg	172 Kg	172 Kg	172 Kg

15 tonnes

Ideal for intense and professional work



RL 15 TRC



**3-POINT SYSTEM
ATTACHABLE TO TRACTOR**

Recommended for tractor
<50 Hp (a 1500 rpm)

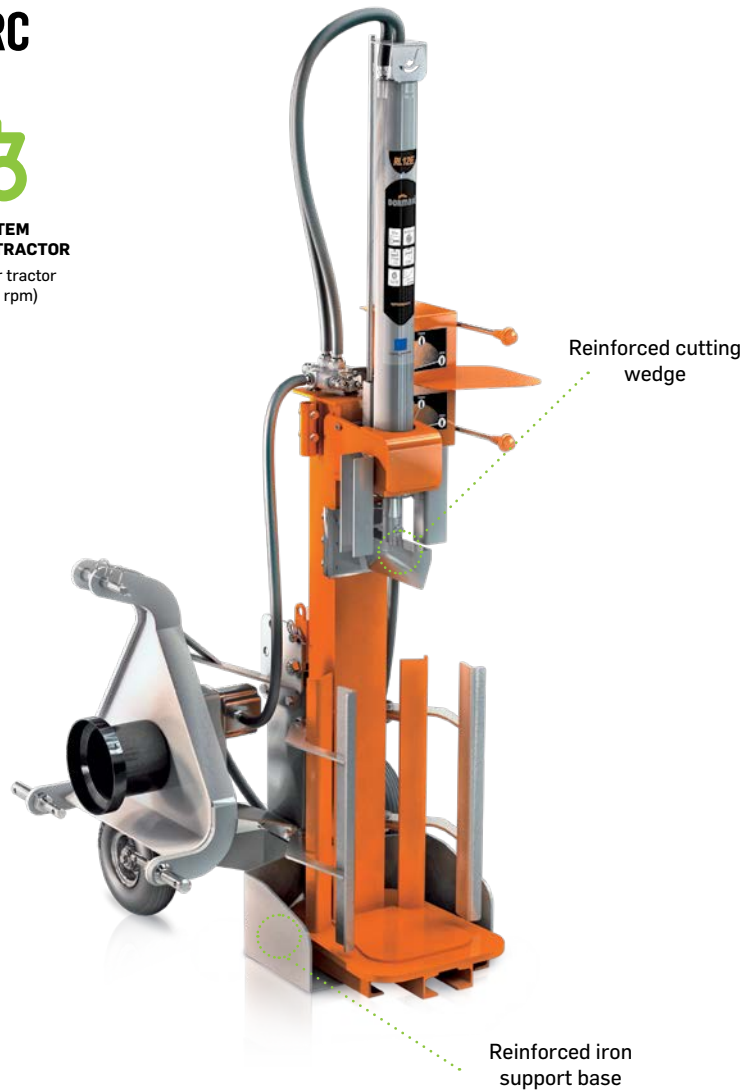

LOG SPLITTERS

	RL15 TRC
Engine	PTO
Displacement	-
Power	-
Max. pressure	15 ton
Max. diameter	700 mm
Speed	Variable
Wheels	2
Hydraulic Oil Tank Capacity	7,5 L
Maximum length of logs	700 mm
Working positions	3
Weight	172 Kg



-  GARDEN
-  FOREST
-  AGRICULTURE
-  WATER
-  LAWN TRACTORS

LOG SPLITTERS

TILLERS

An extensive range that covers all the needs when preparing the land. Extremely efficient machines with various engines that are easy to manoeuvre and can be used for both private and professional work.



STRONG CHASSIS

Steel chassis and reinforced structure

EASY TO USE

Ergonomic fixed or adjustable handlebars, allowing better comfort of use

WIDE RANGE OF ACCESSORIES

THE RANGE

MD35 - MD45 - MD50 - MD60

DORMAKTM
LIFETIME GARDEN EQUIPMENTS

Series
HOME

Series
PRO

- GARDEN
- FOREST
- AGRI
- WATER
- LAWN TRACTORS

highlight MD 60 H PLUS



DORMAK DETAILS



Front wheel for easy transport



Screw blades for easy replacement



Handlebars that are adjustable in height

Dormak tillers are very versatile machines. The range covers the needs of all types of work, from smaller machines for hoeing to those for more intensive work where higher speeds are required. With front or rear transport wheel solutions, multi-position handlebars and bolt-on or welded blades, everything is adaptable to the needs of each user.

NEW

MD 35

**POWERFUL AND
COMFORTABLE
TILLER**



Thought out in detail.....

The new MD 35 tiller has been thought and designed with portability as a main criteria, keeping the width of the blades for more demanding works. Light and compact, this tiller has a double rear wheel and a depth control indicator, being a versatile machine, serving both for hoeing and digging. It replaces the older and much requested MD 40, to make the range wider to cover all necessities.



POWERFUL TILLER

COMFORTABLE TILLER

ADAPTED TO YOUR NEEDS



PORTABILITY
Combined with a good working width

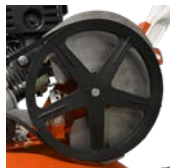

**RIGID PLASTIC
STRUCTURE**



KEVLAR BELT



**DOUBLE REAR
FOLDING WHEEL**



DEPTH CONTROL



**QUICK CONNECT
HANDLEBAR**

MADE IN EUROPE

small areas

Ideal for low intensity work



MD 35 L PLUS



MD 35 L ECO

MD 35 L

MD 35 L PLUS

	MD 35 L ECO	MD 35 L	MD 35 L PLUS
Engine	Loncin	Loncin	Loncin
Hp/kW/cc	80 cc	80 cc	80 cc
Speed	1 F	1 F	1 F
Transmission	Belt	Belt	Belt
Working width	360 mm	480 mm	510 mm
Handlebar	1 Position	1 Position	1 Position
Blade type	Dig	Dig	Dig
Blade Fitting	Welded	Welded	Screwed
Depth control	Fixed	Fixed	Fixed
Transport wheels	-	2 Rear	2 Rear
Chassi	2 mm	2 mm	2 mm
Weight	28 Kg	28 Kg	28 Kg

medium areas

Ideal for medium intensity work



MD 45 L



	MD 45 L	MD 50 L ECO	MD 50 BS ECO	MD 50 H ECO
Engine	Loncin	Loncin	B&S CR750	Honda GP 160
Hp/kW/cc	79 cc	6,6Hp / 4,1kW / 196cc	- / 3,3kW / 163cc	4,8Hp / 3,6kW / 163cc
Speed	1F + 1T	1F + 1T	1F + 1T	1F + 1T
Transmission	Belt	Belt	Belt	Belt
Working width	600 mm	600 mm	600 mm	600 mm
Handlebar	Height adjustable	Height adjustable	Height adjustable	Height + side adjustable
Blade type	Dig	Dig	Dig	Dig
Depth control	Fixed	Fixed	Fixed	Fixed
Transport wheels	1	1	1	1
Chassi	2 mm	2 mm	2 mm	2 mm
Weight	38 Kg	52 Kg	52 Kg	52 Kg

Ideal for medium intensity work

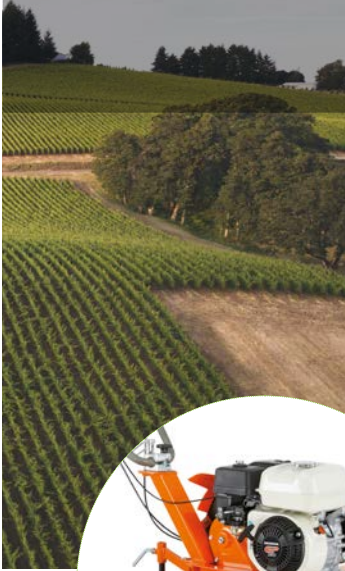

MD 50 H PLUS



	MD 50 L PLUS	MD 50 BS PLUS	MD 50 H PLUS
Engine	Loncin	B&S CR 750	Honda GP 160
Hp/kW/cc	6,6Hp / 4,1kW / 196cc	- / 3,3kW / 163cc	4,8Hp / 3,6kW / 163cc
Speed	1F + 1T	1F + 1T	1F + 1T
Transmission	Belt	Belt	Belt
Working width	900 mm	900 mm	900 mm
Handlebar	Height + side adjustable	Height + side adjustable	Height + side adjustable
Blade type	Dig	Dig	Dig
Depth control	Adjustable	Adjustable	Adjustable
Transport wheels	1	1	1
Chassi	3 mm	3 mm	3 mm
Weight	57 Kg	57 Kg	57 Kg

big areas

**Ideal for
intense and
professional
work**



MD 60 H PRO PLUS



	MD 60 L	MD 60 BS PRO PLUS	MD 60 H PRO PLUS
Engine	Loncin	B&S 750	Honda GP200
Hp/kW/cc	6,6Hp / 4,1kW / 196cc	- / 3,3kW / 163cc	5,5Hp / 4,1kW / 163cc
Speed	2F + 1 T	2F + 1T	2F + 1T
Transmission	Box and Belt	Box and Belt	Box and Belt
Working width	900 mm	900 mm	900 mm
Handlebar	Height + side adjustable	Height + side adjustable	Height + side adjustable
Blade type	Dig	Dig	Dig
Depth control	Adjustable	Adjustable	Adjustable
Transport wheels	1	1	1
Chassi	4 mm	4 mm	4 mm
Weight	65 Kg	65 Kg	65 Kg

ACCESSORIES



SCREW BLADES MD40
Ref. 205001EM041FP

SCREW BLADES (STD) COMPLETE MD50
Ref. 205000000D320

SCREW BLADES (STD) COMPLETE MD60
Ref. 2050600000600

SCREW BLADES (STD) COMPLETE MD60
Ref. 2050600000650



ADDITIONAL STAR PAIR MD50 (includes mudguard)
Ref. 050000061679



REVERSIBLE PLOW Fixed RODS MD50 and MD60
Ref. 205000000VF00



RIGGERS WITH METALLIC WHEELS MD50
Ref. 205000CRATK54

ADJUSTABLE DRESSER WITH METAL WHEELS MD60
Ref. 2050600000CRA

ADJUSTABLE RUG OPENER MD50 and MD60
Ref. 205000000AEON

ADJUSTABLE RUG OPENER AB01
Ref. 205000000AB01



METALLIC WHEELS PAIR MD50
Ref. 2050000540KIT

METALLIC WHEELS PAIR MD60
Ref. 20506000KIT+E

METALLIC WHEEL PAIR RM01
Ref. 205000000RM01



WHEEL PAIR 400.08 W/ FIXED AXIS 205mm (round shaft) MD50
Ref. 20500000004-8

WHEEL PAIR 400.08 W/ FIXED AXIS 305mm (round shaft) MD50
Ref. 2050004-8-305

WHEEL PAIR 400.08 W/ FIXED AXIS HEXAGON MD600
Ref. 20506000004-8

PAIR OF PNEUMATIC WHEELS RP01 + HEXAGONAL AXLESS
Ref. 205000000RP01

WHEELS PAIR 500.10 C/ HEXAGONAL SHAFT MD600
Ref. 205060RT50010



PAIR OF WHEEL WEIGHTS 400.08 29KG MD50 and MD60
Ref. 20500PT400.08



POTATO PULLERS MD50 and MD60
Ref. 205000000AP00

POTATO PULLERS AR01
Ref. 205000000AR01

SPRAYERS

A spayer or a motosprayer is a great help for agricultural and disinfestation tasks. With Dormak's wide range of products, you can address any necessity for tasks of pulverization of pesticides, herbicides, and fertilizers. With capacity for several meters of hose, it allows you to make a collective or individual application on plants, shrubs and trees as well as in vegetable gardens and vineyards.



TRANSPORTABLE

With a metal stand, wheels and handles you can move your sprayer anywhere.

VARIOUS DISTANCES

It can be equipped with a reel and various hose sizes, allowing the user to increase its range of action.

VARIOUS ENGINES

Choose your engine, between lighter and stronger powers, so you can adapt to the necessity of your work.

THE RANGE

SD14 - SD16 - SD20 - SD25 - SD40 - SD45 - SD100

DORMAKTM
LIFETIME GARDEN EQUIPMENTS

Series
HOME

Series
PRO

- GARDEN
- FOREST
- AGRI
- WATER
- LAWN TRACTORS

highlight **SD 100**



DORMAK DETAILS



Reel for 50 meters of hose



Large wheels adapted to capacity



Wide deposit entrance

Dormak motosprayers have one of the most attractive designs on the market and are equipped with a high quality reel and hose, where every component is made in Europe. The models are all extremely balanced, thanks to the system of 1 or 2 wheels depending on their capacity.



SPRAYERS

45 liters

Ideal for smaller areas



SD 45/14



ADJUST THE STANDARD VERSIONS OF OUR SPRAYERS TO YOUR NEEDS, WITH ADDITIONAL ACCESSORIES:
· Hose 20 Bar or 50 Bar · Spear of 1 and 1,5 meters · Hose reels

OFFER

Reel and hose 25 mt

EQUIPPED WITH:

Spear 60 cm + 10 m hose, does not include reel neither its structure.



	SD 16 LI	SD 45/14	SD 45/14 1 Wheel	SD 45/14 2 Wheels
Engine	Dormak 12V	Dormak	Dormak	Dormak
Hp / kW / cc	-	25,6 cc	25,6 cc	25,6 cc
Type of engine	Electric	2 T	2 T	2 T
Pump	-	14 bar	14 bar	14 bar
Spear	-	60 cm	60 cm	60 cm
Deposit Cap.	16 L	45 L	45 L	45 L
Wheels	-	1	1	2
Type of pump	-	Piston	Piston	Piston

100 liters



Ideal for bigger areas

SD 100/40 H PRO



- GARDEN
- FOREST
- AGRI
- WATER
- LAWN TRACTORS

SPRAYERS

EQUIPPED WITH:

Spear 60 cm + 10 m hose, does not include reel neither its structure.



	SD 100/20 L	SD 100/20 BS	SD 100/25 L	SD 100/40 H PRO
Engine	Loncin	B&S CR 750	Loncin	Honda GX160
Hp / kW / cc	79 cc	163 cc	4,1 Kw / 196 cc	5,5 Hp / 4,1 kW / 163 cc
Type of engine	4 T	4 T	4 T	4 T
Pump	20 bar	20 bar	25 bar	40 bar
Spear	60 cm	60 cm	60 cm	60 cm
Deposit Cap.	100 L	100 L	100 L	100 L
Wheels	2	2	2	2
Type of pump	Double membrane	Double membrane	Double membrane	Double membrane

* merely figurative engine image

no deposit

EQUIPPED WITH
Spear 60cm
+ 10m hose + Suction hose

**Ideal for
connecting
directly to the
deposit**



SD 40 HX



Highly resistant
steel structure

Pneumatic wheels



HOSE 10m



**SUCTION
TUBE**



**SPEAR
60cm**

EQUIPPED WITH: Spear 60 cm + 10 m hose, does not include reel neither its structure.



	SD14DK	SD20L	SD20BS	SD25L	SD40HX
Engine	Dormak	Loncin	B&S 750	Loncin	Honda GX160
Hp / kW / cc	25 cc	5,5 Hp / 4,1 kW / 196 cc	- / 3,3 kW / 163cc	5,5 Hp / 4,1 kW / 196 cc	5,5 Hp / 4,1 kW / 163 cc
Type of engine	2 T	4 T	4 T	4 T	4 T
Pump	14 bar	20 bar	20 bar	25 bar	40 bar
Spear	60 cm	60 cm	60 cm	60 cm	60 cm
Deposit Cap.	-	-	-	-	-
Wheels	Chassi + Wheels	Handle + wheels	Handle + wheels	Handle + wheels	Handle + wheels
Type of pump	Piston	Double membrane	Double membrane	Double membrane	Double membrane

* merely figurative engine image

ACCESSORIES

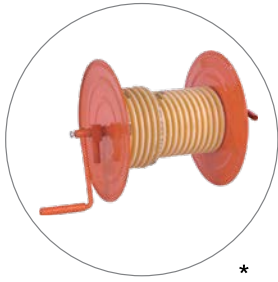

MOTOSPRAYER REEL 50M *
Ref. 202A000000004

MOTOSPRAYER REEL PARA 100M *
Ref. 202A000000005

* Does not include hose



REEL STRUCTURE 50M (100L)
Ref. 202A000000010

REEL STRUCTURE DE 100M (100L)
Ref. 202A000000009



HELIVYL TUBE P20 8MM 20 BAR

ROLL 25 mt
Ref. 2028A0242.025

ROLL 50 mtt
Ref. 2028A0242.050

ROLL 100 mt
Ref. 2028A0242.100

HELIVYL TUBE P50 8mm 50 BAR



SPEAR 0,60m
Ref. 202A000000001

SPEAR 1m
Ref. 202A000000002

SPEAR 1,5m
Ref. 202A000000003



RIDERS

DORMAK™

Dormak's riders promise a unique experience with the new range of lawn tractors. Built and designed from scratch, they feature top of the range transmission and enough power to tackle any type of terrain, whether low or tall grass.



SAFE

Presence of elements such as a superior protection ring against accidents to make the user comfortable and confident.

DESIGN

Based on the best references on the market, the design was thought to reflect the Dormak brand and present the most beautiful and comfortable tractor to handle.

ROBUST

The build quality is present in every detail of the machine, with a reinforced chassis for long term durability.

THE RANGE

RXH80 - RXH95

DORMAKTM
LIFETIME GARDEN EQUIPMENTS

Series
HOME

Series
PRO



GARDEN



FOREST



AGRI



WATER



LAWN
TRACTORS

highlight RXH 95



DORMAK DETAILS



Innovative cutting system for greater efficiency



Pedal and handbrake system

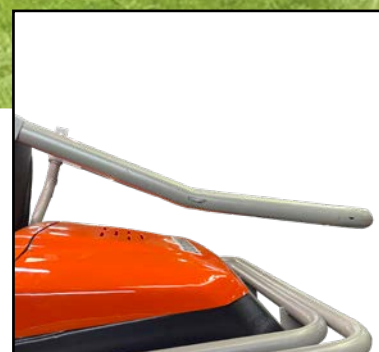

Protective frame with hinge

Dormak riders are designed with a pioneering cutting system, crash protection rim and pneumatic wheels to tackle any surface. The front and rear bumpers help both to lower tall grass for cutting and to protect in adverse situations. They have a pedal system instead of a lever in the bigger model for greater comfort, with variable forward and reverse speeds.

MADE IN EUROPE



EVOLUTION STEP BY STEP...

In 2021, Dormak decided to start producing Riders, a pioneering project in Portugal, which involved a major I&D effort for over a year.

Following an ever-increasing need for riders, Dormak is increasing its offer in more professional segments for the treatment of larger areas.

The engines offered guarantee more than enough power from easy surfaces to the most demanding ones.

The machines have been tested over many months and fine-tuned according to the user's efficiency and comfort.

It has the innovative **Dormak Cutting System**, a transmission of the highest performance, pedal or lever for acceleration depending on the model, brake system, among other details that promise to surprise you.

DORMAK CUTTING SYSTEM (DCS)

An innovative blade system developed by Dormak based on its know-how and best market practices. The **Dormak Cutting System** is composed by:

- 1) a mulching blade
- 2) a blade with loose ends, flexible to absorb impact from stones and other hard materials without any difficulty. Makes cutting significantly more effective.

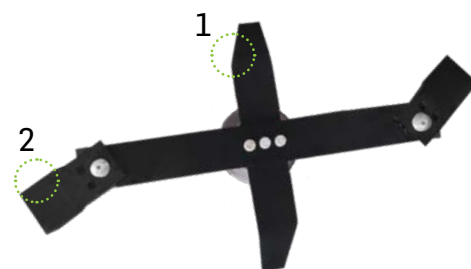

big areas

RXH 95



-  GARDEN
-  FOREST
-  AGRI
-  WATER
-  LAWN TRACTORS

RIDERS

	RXH 80 16	RXH 80 20	RXH 95 16	RXH 95 20
Engine	Loncin	Loncin	Loncin	Loncin
Displacement	452 cc	608 cc	452 cc	608 cc
Power	16,5 Hp	20 Hp	16,5 Hp	20 Hp
Recommended Use	7500 m ²	7500 m ²	10000 m ²	10000 m ²
Cutting Width	780 mm	780 mm	860mm	860mm
Cutting system	DCS	DCS	DCS	DCS
Cutting height	Min. 40 mm Max. 110 mm	Min. 40 mm Max. 110 mm	Min. 40 mm Max. 110 mm	Min. 40 mm Max. 110 mm
Mulching	Yes	Yes	Yes	Yes
Transmission	Hydro Gear T3	Hydro Gear T3	Hydro Gear G700	Hydro Gear G700
Clutch de Blade	Electromagnetic	Electromagnetic	Electromagnetic	Electromagnetic
Collection bag	No	No	No	No
Acceleration system	Lever	Lever	Pedal	Pedal
Speed	Continuous speed from 0Km to 9Km/h	Continuous speed from 0Km to 9Km/h	Continuous speed from 0Km to 9Km/h	Continuous speed from 0Km to 9Km/h
Wheels	Front 13" X 5" - 6" Back 16" X 6.5" - 8"	Front 13" X 5" - 6" Back 16" X 6.5" - 8"	Front 16" X 6.5" - 8" Back 20" X 10" - 8"	Front 16" X 6.5" - 8" Back 20" X 10" - 8"
Dimensions (H x W x L)	190 cm x 102 cm x 170 cm	190 cm x 102 cm x 170 cm	200 cm x 102 cm x 170 cm	200 cm x 102 cm x 170 cm
Weight	280 Kg	292 Kg	300 Kg	312 Kg

GARDEN TRACTORS

Our ride-on mowers are prepared to perform any type of work quickly and with ease. They have the versatility needed to ensure comfort and control, guaranteeing you safe use. Leave the lawn well-kept and charming, for you to enjoy it to the fullest!

DORMAKTM



SAFE

Equipment tested and prepared for various scenarios with effective security systems

DESIGN

Designed and developed for a perfect combination of elegant lines, performance and comfort in handling the machine.

ROBUST

Build quality is present in every detail of the machine, with a reinforced chassis for above average durability.

THE RANGE

TXH95 - TXH105 - DK86 - DK92 - DK98 - DK102 - DK108

highlight TXH 105 PRO

DORMAKTM

LIFETIME GARDEN EQUIPMENTS

Series
HOME

Series
PRO



GARDEN



FOREST



AGRI



WATER



LAWN
TRACTORS



DORMAK DETAILS



Hydrostatic



Centralized regulation
cutting height



Cutting system with 2
blades

The range of tractors Dormak presents a very varied offer, from leisure to more professionals.



big areas

Ideal for professional work on larger areas



TXH 95 DK



GARDEN TRACTORS



HYDROSTATIC



2 BLADES



**HEIGHT ADJUSTMENT
CENTRALIZED FOR 6
POSITIONS**



**ELECTROMAGNETIC
BLADE CLUTCH**

DETAILS OF TXH95 DK AND TXH 105 PRO



Small turning radius, allows a comfortable ride and excellent obstacle avoidance



Simple capot opening for engine access



Deck equipped with wheels for uniform cutting



Large smooth lawn tires



Equipped with LED lights



Command elements ergonomically arranged

big areas

TXH 105 PRO

Simplify cutting and maintenance tasks in your garden and have more time for what you enjoy most.



Automatic collection bag



2 blade cutting system



Ergonomic steering wheel

-  GARDEN
-  FOREST
-  AGRI
-  WATER
-  LAWN TRACTORS

GARDEN TRACTORS

	TXH 95 DK	TXH 105 PRO
Engine	Dormak Euro 5	B&S Intek 7160 V2
Displacement	452 cc	656 cc
Power	7,7 kW / 2600 rpm	9,1 kW / 2450 rpm
Recommended Use	7000 m ²	8000 m ²
Cutting Width	950 mm	1020 mm
Cutting system	2 Blades	2 Blades
Cutting Height	6 Positions 30 to 80 mm	6 Positions 30 to 80 mm
Mulching	No	No
Transmission	Hydrostatic	Hydrostatic
Blade clutch	Electromagnetic	Electromagnetic
Collection bag	220 L	300 L
Speed	Variable	Variable
Wheels	Front 15" x 6.0" - 6" Back 18" x 8.5" - 8"	Front 15" x 6.0" - 6" Back 18" x 8.5" - 8"
Dimensions (L x W x H)	239 x 102 x 114 cm	239 x 110 x 114 cm
Weight	227 Kg	242 Kg

big areas

For professional work on larger areas

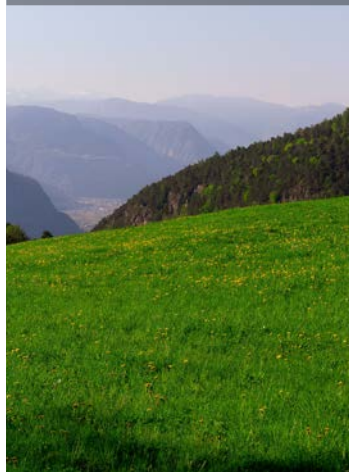

DK 102 H



Collection bag

Ergonomic steering wheel

Speed lever
5 Front + 1 Rear

Protection bumper

	DK 86 H	DK 92 H	DK 102 H
Engine	Dormak	Dormak	Dormak
Displacement	452 cc	546 cc	686 cc
Recommended Use	3500 m ²	3500 m ²	5000 m ²
Cutting Width	860 mm	920 mm	1020 mm
Cutting system	2 Blades	2 Blades	2 Blades
Cutting Height	8 Positions 30 to 80 mm	7 Positions 30 to 80 mm	8 Positions 30 to 80 mm
Mulching	Yes	Yes	Yes
Transmission	Hydrostatic	Hydrostatic	Hydrostatic
Blade clutch	Electromagnetic	Electromagnetic	Electromagnetic
Collection bag	245 L	245 L	245 L
Speed	0 to 9 km/h	0 to 9 km/h	0 to 9 km/h
Wheels	Front 15" x 6.0" Back 18" x 8.5"	Front 15" x 6.0" Back 18" x 8.5"	Front 15" x 6.0" Back 18" x 8.5"
Dimensions (L x W x H)	242 x 110 x 114 cm	242 x 110 x 114 cm	242 x 110 x 114 cm
Weight	210 Kg	215 Kg	221 Kg

big areas

For professional work on larger areas



DK 108 SH



	DK 86 SH	DK 98 SH	DK 108 SH
Engine	Dormak	Dormak	Dormak
Displacement	352 cc	552 cc	546 cc
Recommended Use	2500 m ²	2500 m ²	5000 m ²
Cutting Width	860 mm	980 mm	1080 mm
Cutting system	2 Blades	2 Blades	2 Blades
Cutting Height	8 Positions 30 to 80 mm	7 Positions 30 to 80 mm	8 Positions 30 to 80 mm
Mulching	Yes	Yes	Yes
Transmission	Hydrostatic	Hydrostatic	Hydrostatic
Blade clutch	Electromagnetic	Electromagnetic	Electromagnetic
Collection bag	-	-	-
Speed	0 to 9 km/h	0 to 9 km/h	0 to 9 km/h
Wheels	Front 15" x 6.0" Back 18" x 8.5"	Front 15" x 6.0" Back 18" x 8.5"	Front 15" x 6.0" Back 18" x 8.5"
Dimensions (L x W x H)	187 x 86 x 104 cm	187 x 86 x 104 cm	187 x 86 x 104 cm
Weight	190 Kg	192 Kg	195 Kg



my DORMAK™

Visit our online store and be surprised
with our entire range of products.

www.dormak.pt



MORE THAN DEVELOPING TOOLS, WE WORK TO EARN TRUST AND DELIVER QUALITY.

More than developing new products, we develop our own technologies,
because we chart our own path. Differentiation, efficiency, pleasure of
use and a good service is always at the center of our strategy.



Zona Industrial de Vagos, Lote 97/98

3840-385 Vagos, Portugal

T. +351234914686 F. +351234912032

info@dormak.pt